

# Acrison®

## WEIGH FEEDERS

Model 203 Weigh Belt  
Model 203B Weigh Auger

*For Dry Solids*

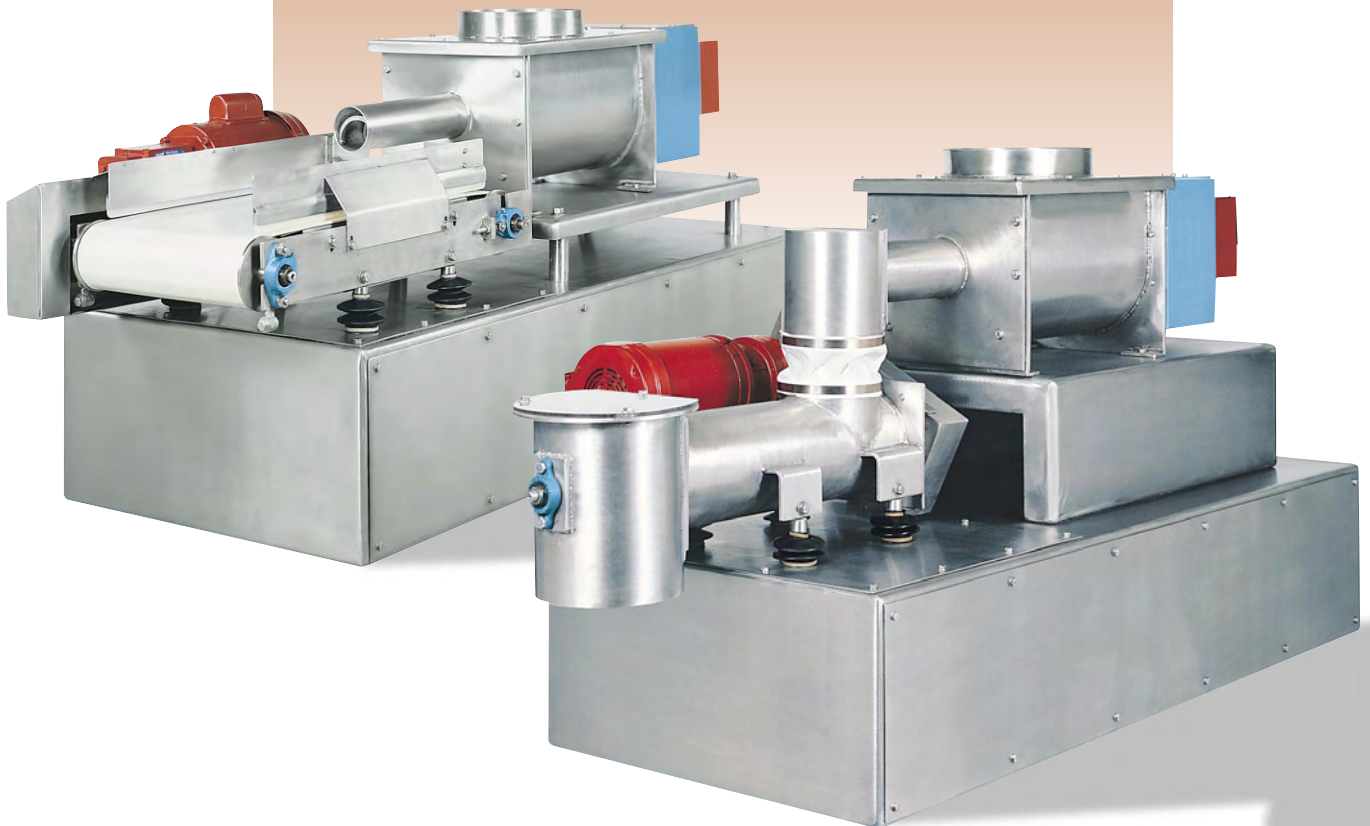

*Advanced design technologies for superior  
performance, quality and reliability.*

# WEIGH FEEDERS

## Model 203 Series

### *For Dry Solids*



Model 203B-105Z  
Weigh Auger  
Weigh Feeder

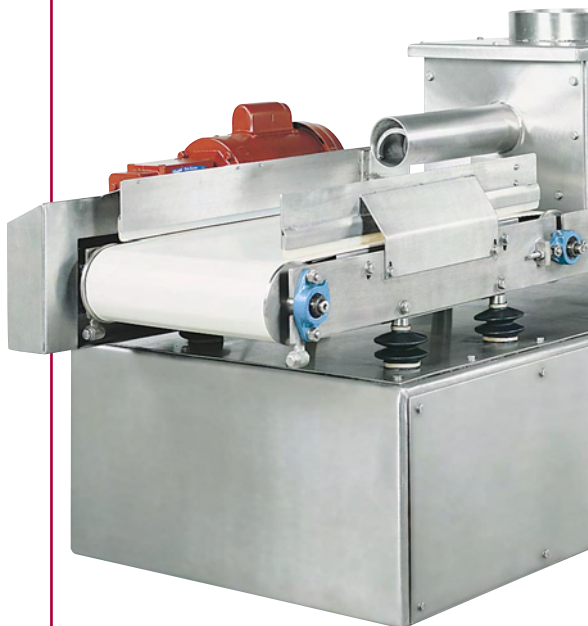

Model 203-105Z  
Weigh Belt  
Weigh Feeder

The Models 203 and 203B Weigh Feeders combine the versatile materials-handling capabilities and reliable metering performance provided by an integral Acrison Prefeeder with a highly responsive weighing and control system.

### Models 203 and 203B Weigh Feeders

Both the Models 203 Weigh Belt and 203B Weigh Auger Weigh Feeders include integral *Prefeeders* to ensure positive and reliable feed of a wide variety of dry solid ingredients onto the Weigh Belt, or into the Weigh Auger, with a high degree of preliminary metering accuracy. In particular, the utilization of an integral Prefeeder is especially advantageous when metering the more “difficult-handling” materials. And because of this initially established accuracy, it’s generally a simple task for the feeder’s weighing and control system to refine the metered output of the *Variable Speed Prefeeder* to produce precise weigh feeder performance in relation to a feed rate selection.

In addition, and although not as versatile as Model 203 Weigh Belt Feeders, Model 203B Weigh Auger Feeders provide total product confinement in an entirely dust-tight configuration.

Weigh Belt and Weigh Auger assemblies are mounted on an Acrison high-resolution, state-of-the-art, counterbalanced lever weighing mechanism where only the net weight of product passing across the Weigh Belt or through the Weigh Auger is weighed. Weight is sensed by Acrison’s exclusive Ratiometric Digital Weight Resolver (see page 4) that inherently produces unamplified resolution capability of over one part in a million.

Model 203 and 203B Weigh Feeders are also mechanically simple, ruggedly constructed and have only a few moving parts. Their weighing mechanisms, including the Ratiometric Digital Weight Resolvers, are entirely calibration and adjustment-free, and guaranteed for five years. They are also extremely durable, require bare minimal maintenance, and boast unsurpassed longevity.

# Models 203 and 203B Weigh Feeders

## Operation

As the Prefeeder discharges product onto the scale-mounted synchronous speed Weigh Belt or Weigh Auger, a proportional-to-weight signal is generated by the Ratiometric Digital Weight Resolver, which is then compared to the selected feed rate. Any difference between these signals results in correction to the feed rate of the Prefeeder, altering its output accordingly — so that the actual output (weighed) feed rate precisely matches the selected feed rate. The Prefeeder is driven by a variable speed drive.

Typically, the accuracy generated by the prefeeder ranges between  $\pm 1$  to 3 percent or better (error) for the majority of ingredients. And, because of this already established preliminary accuracy, little correction in the feed rate output of the Prefeeder is usually required to achieve highest levels of weigh feeder performance. The result is a uniform and extremely accurate flow of material.

## Features

- **Metering Accuracy:** Metering accuracy is typically  $\pm 0.25$  to 1 percent or better (error) at two sigma, based on a given number of consecutive one minute weighments.
- **Weighing System Specifications:** See page 4.
- **Versatility:** The appropriate model Prefeeder ensures dependable metering of a wide range of dry solid ingredients regardless of handling characteristics.

### • Output Capacities:

- For Model 203 Weigh Belt Feeders, the total output capacity ranges from 60 to 48,000 pounds per hour.
- For Model 203B Weigh Auger Feeders, the total output capacity ranges from 120 to 136,000 pounds per hour.

**Note:** Output capacities are based on a product weighing 40 pounds per cubic foot.

- **Feed Range:** The feed range for both the Models 203 and 203B Weigh Feeders is 20:1 from the maximum designed output capacity of the particular feeder model.
- **Ambient Temperature Operating Range:** All Acrison weigh feeders are designed to operate within an ambient temperature range of  $-10$  to 140 degrees Fahrenheit.
- **Controls:** Please see page 7.
- **Electrical:** Power requirements are either 115/1/60 or 230/1/60 depending upon the feeder model and size. All motors are totally enclosed.

As an indication of Acrison's confidence level in this equipment, the entire weighing mechanism of the weigh feeder, including its Ratiometric Digital Weight Resolver, is guaranteed for five years from the date of shipment.

## Basic Functional Diagram

Illustration shows a Model 203 Weigh Belt Feeder

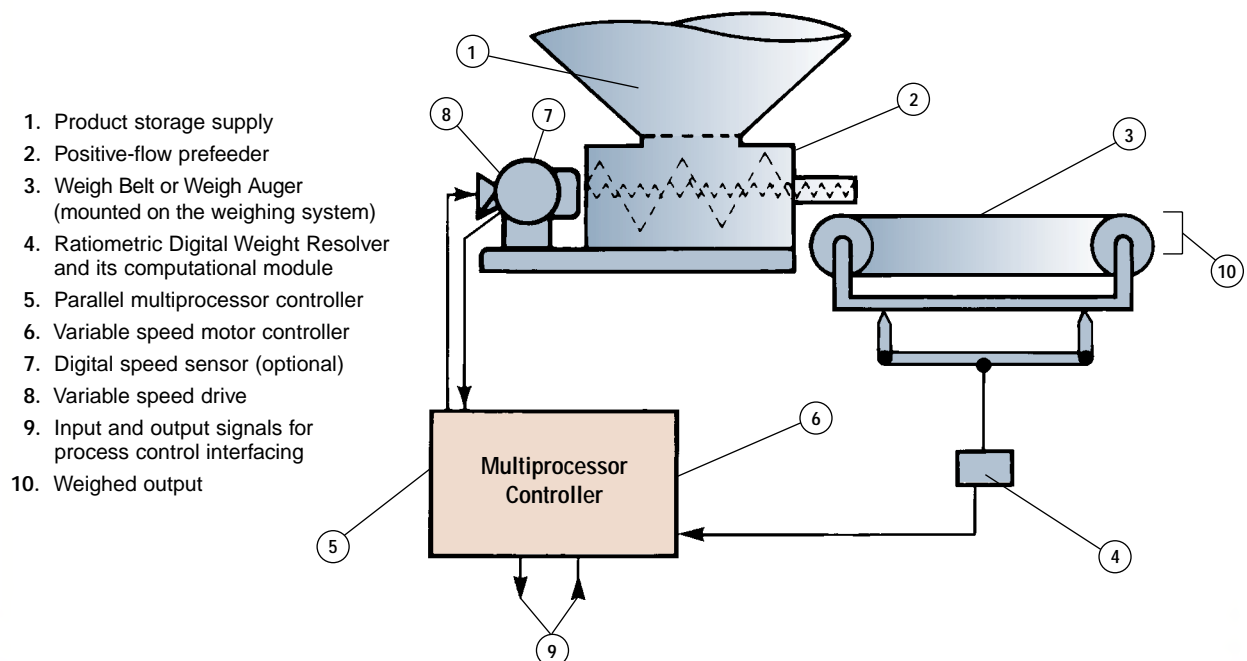

# Models 203 and 203B Weigh Feeders

## Platform Lever Weighing System with Acrison's exclusive Ratiometric® Digital Weight Resolver

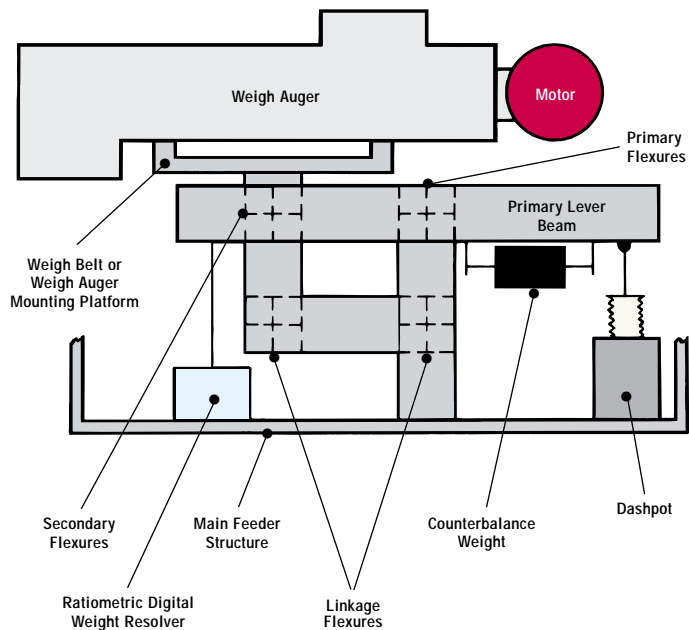

Illustration shows a Model 203B Weigh Auger Feeder

The basic Weighing System used with the Models 203 and 203B Weigh Feeders is a uniquely configured modified parallelogram type lever network utilizing Acrison designed and manufactured flexures for all connecting (pivotal) connections. This technologically advanced weighing mechanism is frictionless in operation, extremely stable, ruggedly constructed, and very precise in its ability to sense weight. The weighing system is also counterbalanced so that only the net weight of material on the Weigh Belt or in the Weigh Auger is weighed.

As noted in the illustration, two *Primary Flexures* connect the *Primary Lever Beam* to the *Main Feeder Structure*, with two *Secondary Flexures* connecting the *Weigh Belt or Weigh Auger Mounting Platform* to the *Primary Lever Beam*. A *Linkage Assembly* (with two additional flexures) connects the lower portion of the *Mounting Platform* to the *Main Feeder Structure*. These rugged, time-proven stainless steel flexures provide optimum structural rigidity of the lever network, both in the horizontal and vertical planes, ensuring permanence of the overall weighing system accuracy and calibration.

As weight is added to, or subtracted from the Weigh Belt or Weigh Auger, the lever network "moves" in an extremely precise relationship to that weight. In turn, this movement is sensed by Acrison's Ratiometric Digital Weight Resolver (RDWR), instantaneously converting this movement into an equally precise signal (unamplified) directly proportional to weight (see below).

In differing from the common variety of load cell based weighing systems, the physical sensing element of the RDWR does not attach to any part of the lever network and therefore, cannot be damaged by any amount of shock or overload that the weighing system may experience. In addition, the entire weighing mechanism, including the RDWR, is completely calibration and adjustment-free, and guaranteed for five years.

## Ratiometric® Digital Weight Resolver System (RDWR)

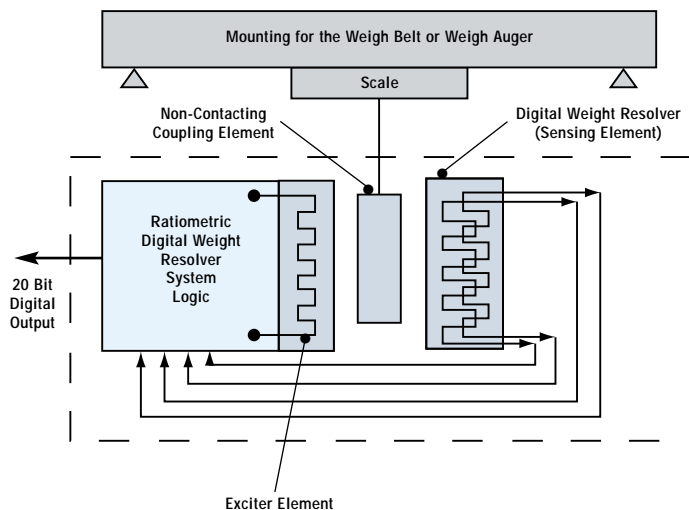

Acrison's exclusive Ratiometric Digital Weight Resolver (RDWR) System, used with all Acrison weigh feeders, computes the linear movement of the lever mechanism (scale) into a true binary coded, serially transmitted data stream having a discrete resolution of 20 bits (or the ability to sense 1 part in 1,048,576). This highly precise and advanced electronic displacement measuring technique basically consists of a sensing element and its computational logic.

The physical sensing component is composed of a series of windings collated on a common element that are equally affected by environmental changes and therefore, self-compensating. In addition, because the computational logic of the RDWR System compares relative measurements, rather than absolute values, its input power source can vary up to  $\pm 30\%$  without affecting the output. Also, all non-weight data, both cyclic and random in nature that may be super-imposed on the actual data, are cancelled-out.

The RDWR System is linear to within 0.01 percent, repeatable to 0.005 percent, possesses long term stability of 0.005 percent (10,000 hours) and carries a 40,000 hour MTBF.

Acrison's RDWR System is FM (Factory Mutual) Approved and Listed for operation in hazardous environments... Classes I, II and III; Divisions 1 and 2; Groups C, D, E, F and G. This weight sensing system also complies with European hazardous area classifications EEx ia IIB T4 and EEx d [ia] IIB T6.

# Model 203 Weigh Belt Weigh Feeders

## Prefeeders

Acrison's Model 203 Weigh Belt Weigh Feeders operate with integral Prefeeders.



Model 203-140-0-P Weigh Feeder  
(shown with dust cover removed)

## Model 203 Weigh Belt Feeders

In many weigh belt applications, the advantages of a prefeed device are numerous. Significant among these advantages is the assuredness of positive, continuous and reliable flow of product onto the weigh belt with a high degree of preliminary accuracy... the type of performance provided by a properly selected Prefeeder. This is especially true when metering the more difficult handling ingredients, some of which simply will not flow onto any weigh belt without an appropriate prefeed device.

In this very crucial area, it is an inherent feature of Acrison's Model 203 Weigh Belt Weigh Feeder to maintain a high degree of prefeed accuracy when metering a broad variety of dry solid ingredients.

*Acrison produces the largest assortment of dry solids metering mechanisms — one to suit the specific handling characteristics of any given product — from basic single auger devices to Acrison's exclusive, dissimilar speed, Double Concentric Auger Metering Mechanisms, to Multiple Auger Bin Discharger Feeders, many of which can be utilized as Prefeeders for Model 203 Weigh Feeders.*

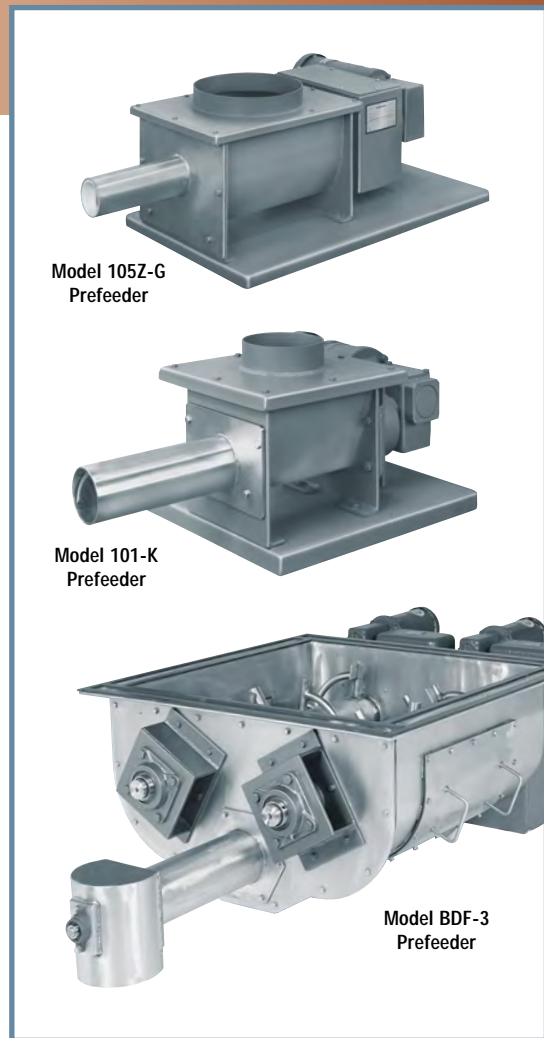

Model 105Z-G  
Prefeeder

Model 101-K  
Prefeeder

Model BDF-3  
Prefeeder

# Model 203B Weigh Auger Weigh Feeders

## Prefeeder

Acrison's Model 203B Weigh Auger Weigh Feeders operate with integral Prefeeder.

Model 203B-105Z-H  
Weigh Feeder

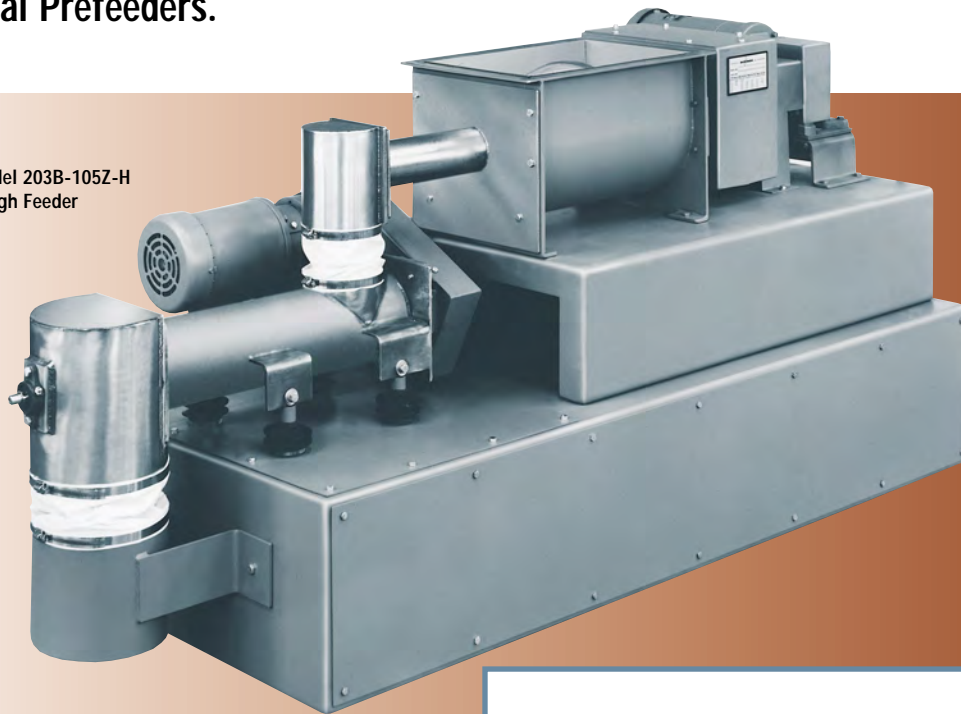

## Model 203B Weigh Auger Feeders

The Model 203B Weigh Auger Weigh Feeder has been designed to operate with an integral Prefeeder to ensure that the Weigh Auger Conveyor receives a continuous and consistent flow of product with a high degree of preliminary metering accuracy.

For a given application, the selected Prefeeder would be one considered most appropriate (based on the physical handling characteristics of the product to be metered), and one that will provide a positive and reliable feed stream of material into the Weigh Auger at all times.

*Acrison produces the largest assortment of dry solids metering mechanisms — one that will suit the specific handling characteristics of any given product — from basic single auger devices to Acrison's exclusive, dissimilar speed, Double Concentric Auger Metering Mechanisms, to Multiple Auger Bin Discharger Feeders, many of which can be utilized as Prefeeder for Acrison's various Model 203B Weigh Auger Feeders.*

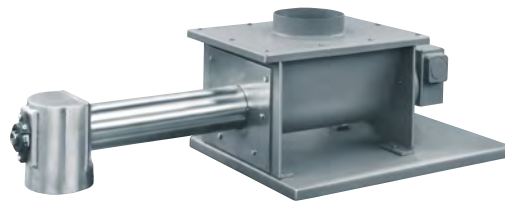

Model 130-P  
Prefeeder



Model 105X-F  
Prefeeder

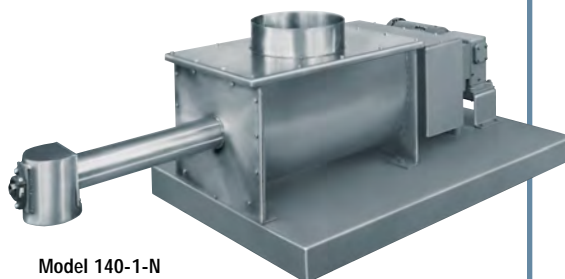

Model 140-1-N  
Prefeeder

# Weigh Feeder Controllers and Control Systems

Acrison Weigh Feeder Controllers and Control Systems are universally recognized for their design superiority, unparalleled versatility, ease-of-use and operational reliability. From basic single weigh feeder controllers to complex multi-feeder supervisory control systems, the technologically advanced designs of these devices, including their cutting-edge software

routines, provide users with unexcelled weigh feeder performance to satisfy the most demanding metering requirements across a broad spectrum of applications. With a wide range of options, accessories and interfacing capabilities, these controllers and control systems are also available in a number of different packaging configurations.

## Acrison Weigh Feeder Controllers

Acrison Weigh Feeder Controllers will operate in either a continuous or batch mode, gravimetrically or volumetrically, and/or in a master/slave or ratio proportioning mode. They are available with a variety of keyboard or graphic touch-screen color displays in various languages and can be provided with recipe storage capabilities as well as with a wide range of I/O interfacing options (i.e., analog, digital, modem, infrared, wireless, serial and network I/O).

For decades, Acrison Weigh Feeder Controllers have provided state-of-the-art performance for thousands of users worldwide. Leading edge products such as the Models C-702, BC-702 and MD-II Family of Controllers, including the MD-II MFC (Multi-Feeder Controller) and the AD-2000 Supervisory System Controller, have gained universal acceptance throughout all sectors of the Processing Industries, and are highly recognized for their versatility and reliability.

## SBC-2000 Weigh Feeder Control Module

Acrison's ongoing investment in research and development continues to result in the evolution of the Company's Controls and Control Systems' capabilities with the launch of the technologically advanced Model SBC-2000 Weigh Feeder Control Module. This new, small and powerful module, encompassing the latest in microcomputer logic and functional algorithms, provides an unprecedented number of standard and optional features, along with broad-scope flexibility for single and multi-feeder control requirements in a compact and cost-effective assembly, particularly those applications that require central computer control, minimal hardware and which do not necessarily require a local user interface or keyboard/display. The advanced SBC-2000 Weigh Feeder Controller can be supplied with various display options if so required.

## Multiple Weigh Feeder Control Systems

Model SBC-2000 Controller Modules, when configured for multi-feeder operation, offer unprecedented ease-of-operation, maximum user flexibility and outstanding performance capabilities. When SBC-2000 Modules are combined with Acrison's AD-2000 Supervisory Control and Software package, it is possible to operate and monitor up to 20 Acrison weigh feeders, while providing rapid data and screen updates, including recipe storage and retrieval, all of which are selectable and operable from the AD-2000 display.

*Reference Design Specifications 1-200-113, 1-200-342, 1-200-0601, 1-200-602, 1-200-627 and 1-200-642 and Bulletin 949.*



All Acrison controllers are certified to UL, CSA and EC specifications.

## Discover the difference!

We cordially invite you to witness a test in Acrison's state-of-the-art Customer Demonstration Facilities handling your actual product(s) with the specific equipment we recommend for the application. Usually, there is no cost or obligation for this service. Discover the difference in technology, quality and performance of Acrison equipment.



## Acrison products...

- Models 101 and 130 Volumetric Feeders
- Models V101 and V130 Volumetric Feeders
- Model 1015 Volumetric Feeder Series
- Model 105 Volumetric Feeder Series
- Model W105 Volumetric Feeder Series
- Model 120 Volumetric Feeder
- Model 140 Volumetric Feeder Series
- Model 170 Volumetric Feeder Series
- Model 200 Series of Weigh Belt Feeders
- Model 203B Series of Weigh Auger Feeders
- Model 270 Series of In-Line Weigh Feeders
- Models 402, 404, A405, 406 and 407 Series ("Weight-Loss-Differential") Weigh Feeders
- Model Series 403 ("Weight-Loss-Differential") Weigh Feeders
- Model 403B (D) Batch/Dump Weighing Systems
- Model 404BZ(BU) Bulk Bag Unloader Batch Weigher
- Models 350 and 301 Continuous Blenders and Blending Systems
- Multiple Auger Bin Dischargers and Multiple Auger Bin Discharger Hoppering Systems
- Multiple Auger Bin Discharger Feeders
- Vibratory Bin Dischargers
- Model 500 Series of Polyelectrolyte Preparation Systems
- Water and Waste Water Treatment Systems
- Volumetric and Gravimetric Feeder Controllers and Control Systems
- Accessory Equipment for Acrison Products
- Systems Engineering

"Visibly Different... Measurably Better"

# Acrison<sup>®</sup>, Inc.

20 Empire Blvd.  
Moonachie, NJ 07074 USA  
201-440-8300 • Fax: 201-440-4939  
Email: [informail@acrison.com](mailto:informail@acrison.com)  
Website: [www.acrison.com](http://www.acrison.com)



Empire Boulevard Facility  
Moonachie, NJ USA



Trafford Park Facility  
Manchester, UK



Joseph Street Facility  
Moonachie, NJ USA

**acrison<sup>®</sup>, INC.**

Copyright 2004—Acrison, Inc.—all rights reserved.  
Acrison is a Registered Trademark of Acrison, Inc., Moonachie, New Jersey  
© Registered Acrison Trademarks  
Domestic and Foreign Patents issued and pending.