

Acrison[®]

Weigh Feeder Model 407X

'Weight-Loss'

For Dry Solid Materials



*Advanced, time-proven technologies for optimum
weigh feeder performance.*

Model 407X Weigh Feeder

'Weight-Loss'

For Continuous or Batch Weigh Feeding Applications

Proven in thousands of installations worldwide, Acrison's 'Weight-Loss' Weigh Feeders, with their exceptionally precise and reliable weighing technology and leading-edge controls, provide users with superior operational performance, lowest maintenance requirements and unexcelled longevity.

Model 407X Weigh Feeder

The Model 407X is a low profile, economically priced weigh feeder employing Acrison's advanced 'Weight-Loss' weigh feeding concepts and designs for accurately and reliably metering a variety of dry solid ingredients at feed rates ranging from approximately ten pounds upwards to thousands of pounds per hour.

Encompassing strong, field-proven weighing technology, specifically developed by Acrison for 'weight-loss' weigh feeding applications, the Model 407X consists of a uniquely configured, open 'platform' type lever weighing system where the selected metering device 'mounts' onto a weigh platform.

The robustly constructed lever weighing network is in itself a 'scale', utilizing frictionless stainless steel flexures for all pivotal connections. As weight (product) is added to or removed from the weigh platform (metering mechanism), the lever network 'moves' in a direct relationship to that weight, which movement is precisely sensed by Acrison's Ratiometric Digital Weight Resolver and instantaneously converted into a highly accurate digital signal directly proportional to weight.

Analogous to the weighing mechanisms used with all of Acrison's various model 'weight-loss' weigh feeders, the Model 407X weighing system is also permanently calibrated and will remain precise without the need for recalibration and/or adjustment. In addition, Acrison weighing mechanisms are not in any way delicate or temperamental and will operate over an ambient temperature range of -20 to 150 degrees Fahrenheit. Optionally, they can be furnished in all stainless steel construction.

The Model 407X Weigh Feeder is available with various model and size Acrison dry solids mechanisms, typically as outlined in this Bulletin.



Model 407X-101-1

Model 407X 'Weight Loss' Weigh Feeder

For Continuous or Batch Weigh Feeding Applications

Basic Function Diagram
[Typical Dry Solids System]

1. Weigh feeder supply hopper
2. Dry solids auger type metering mechanism
3. Weighing system with Ratiometric Digital Weight Sensor (3A)
4. Multiprocessor controller
5. Variable speed motor controller
6. Digital speed sensor (DC drive)
7. Variable speed gearmotor
8. Input/output signals for process control interfacing
9. Product storage supply
10. Automatic refill mechanism
11. Refill feeder in lieu of refill mechanism (#10) - can also attach to product storage supply (#9)
12. Flexible connection
13. Weighed output

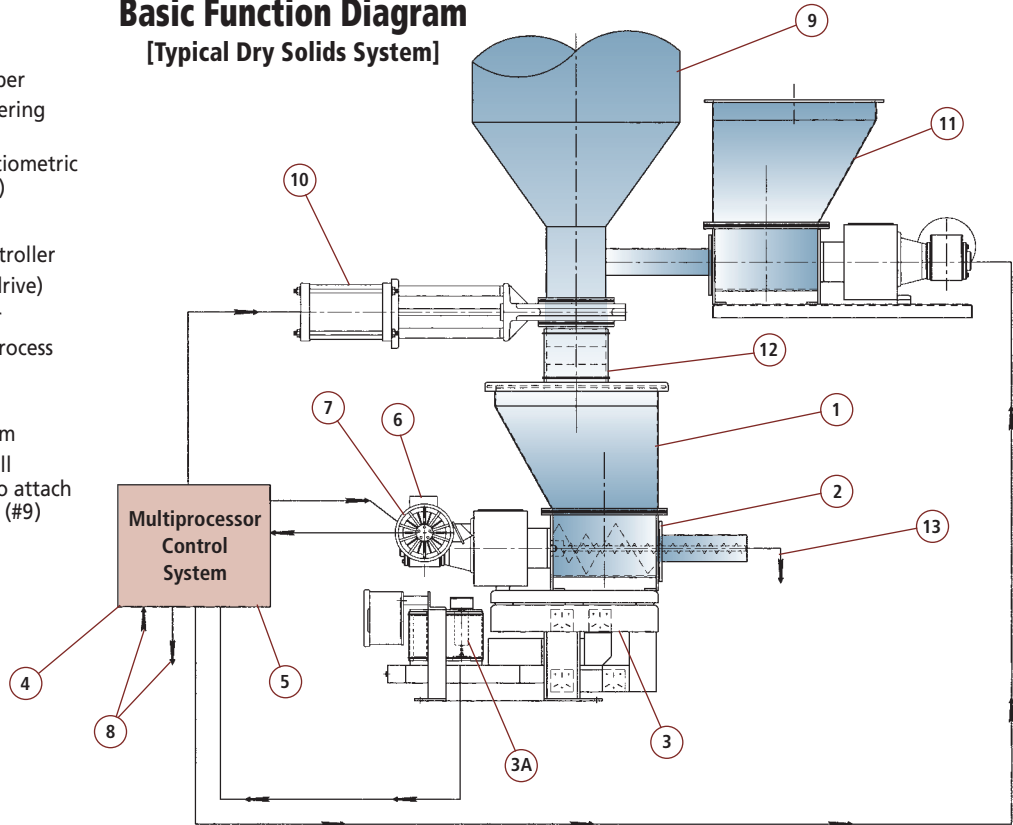

Principles of Operation

As product discharges (feeds) from the scale-mounted metering mechanism, Acrison's ultra-high resolution Ratiometric Digital Weight Sensing System continuously transmits precise 'loss-of-weight' data to the feeder's controller on a 'real time' basis. In turn, the controller calculates the rate at which product is discharging (feeding) and compares that data to the feed rate selection, while simultaneously modulating the variable speed drive of the metering mechanism to precisely maintain the specified feed rate. Response of the metering mechanism is instantaneous, thus achieving smooth short-term accuracy with the highest possible degree of long-term performance.

Unlike weigh feeders that utilize one or more load cells for sensing weight, the weight signal of Acrison weigh feeders is not integrated (averaged) or in any way manipulated for stabilization purposes; it is inherently stable for direct use by the feeder's control system. Signal integration, while giving the impression of good operational stability, can severely hamper a feeder's ability to respond quickly to changes in weight, compromising metering accuracy.

Easily capable of withstanding the harshest industrial environments, Acrison's time-proven, rugged duty weighing systems are unsurpassed in precision, durability, reliability

and longevity. In addition, they are also permanently calibrated and virtually maintenance-free.

The 'weight-loss' principle for continuous weigh feeding requires periodic refilling of the feeder's supply hopper (or tank for liquid applications) as an operational requirement, which is usually a completely automatic function. Frequency of refills is determined by the feed rate throughput relative to the size of the feeder's supply hopper (or tank) within the necessary parameters to ensure optimum weigh feeder performance.

All Acrison 'Weight-Loss' Weigh Feeder control systems also include 'Acri-Lok'®, an Acrison innovation that ensures accurate product delivery should the feeder's weighing system sense an abnormal disturbance during operation.

The entire weighing mechanism of an Acrison weigh feeder, including its Ratiometric Digital Weight Sensor (and associated electronics), is guaranteed for five years.

Continuous metering accuracy typically ranges between +/- 0.25 to 1 percent or better (error) at two sigma, based on a given number of consecutive one minute weighments.

Standard Design Features

- **Continuous or batch weighing on a 'weight-loss' basis** – Acrison's 'weight-loss' operational concepts and equipment designs combine advanced weighing technologies with the most versatile dry solids metering/handling mechanisms and controls to provide users with an unsurpassed level of overall performance.
- **Accuracy** – All Acrison continuous weigh feeders typically provide metering accuracies ranging between ± 0.25 to 1 percent or better (error), at two sigma, based on a given number of consecutive one minute weighments. Batch accuracies typically range between ± 0.1 to 0.5 percent or better (error), at two sigma, based on a given number of consecutive weighments.
- **No response lag** – Acrison's various metering mechanisms respond instantaneously upon command from the controller to alter the feed output. Absolutely no lag exists since product discharges directly out of the scale-mounted metering device.
- **Feed range** – As standard, all Acrison 'weight-loss' weigh feeders are capable of an overall feed range of 100:1
- **Feed output capacity** – The Model 407X Weigh Feeder is capable of an output capacity ranging from about 10 pounds upwards to approximately 4500 pounds per hour, based on a product weighing 40 pounds per cubic foot.
- **Weighing System** – Acrison's various weighing systems are the most durable, reliable, and accurate in the industry. The technologically advanced lever mechanisms of these frictionless, ultra-high resolution counterbalanced weighing systems have been specifically designed for tough industrial 'weight-loss' weigh feeding applications. They are also designed with an uncommonly high service factor easily capable of withstanding the continual 'impacts' associated with refilling without any adverse consequences.
Also, once calibrated (factory completed), these weighing systems do not require any type of mechanical re-calibration or adjustment. In fact, such provisions do not exist; the weighing systems are permanently calibrated.
- **Ratiometric Digital Weight Resolver (RDWR)** – Acrison's Ratiometric Digital Weight Sensing System utilizes synchro-resolver technology and innovative electronics to produce a digital weight signal having extraordinary performance specifications. This unamplified, non-integrated, highly precise and stable weight signal is a count ranging from 0 to 1,048,576 (20 bits), capable of use by any of Acrison's multiprocessor weigh feeder controllers. The Ratiometric System is FM (Factory Mutual) Approved and Listed for operation in hazardous environments... Classes I, II, and III; Divisions 1 and 2; Groups C, D, E, F, and G, and also complies with hazardous area classifications ATEX 3D or IECEx (Zone 22), 3G (Zone 2) and 2D (Zone 21).
- **No rezeroing** – Acrison's 'weight-loss' principle of operation does not require a 'scale' zero reference point; thus, rezeroing the weighing system is never required.
- **Acric-Lok®** – All Acrison 'weight-loss' weigh feeders include a unique operational feature... *Acric-Lok*... developed and patented by Acrison to ensure accurate metering whenever the weighing system is disturbed in any manner that would otherwise adversely affect the accuracy of the metered output.
- **Batch-Lok®** – In addition to *Acric-Lok*, should an abnormal disturbance be detected by the weighing system of an Acrison 'weight-loss' weigh feeder operating in a batching mode, a supplementary feature... *Batch-Lok*... is provided to ensure the highest possible degree of batch accuracy.
- **Automatic refilling** – All Acrison 'weight-loss' weigh feeder control systems provide for automatic refilling of the feeder's integral supply hopper. When automatically refilled, the controller initiates a refill command upon sensing low hopper level, once the feed rate output is within pre-established tolerances.
During the refill period, the feeding mechanism operates in a volumetric mode, returning to gravimetric control after refill and when the controller senses a normal 'weight-loss' condition. In addition, Acrison 'weight-loss' controllers include a number of very effective operational features specifically designed to ensure optimum metering accuracy during all phases of refill, when the feeder is not in gravimetric control.
- **Unaffected by typical in-plant vibration and dust** – Typical in-plant vibrations do not affect Acrison weigh feeders as proven in scores of installations. The novel mechanical design of Acrison weighing mechanisms inherently provides excellent resistance to in-plant vibrations without the need to integrate the actual weight signal for stability purposes. Also, based on the 'weight-loss' principle of operation, dust accumulation onto any part of the weigh feeder will not adversely affect metering performance.
- **Ambient operating temperature range** – All Acrison weigh feeders will operate within an ambient temperature range of -20 to 150 degrees Fahrenheit without any affect on performance.
- **Totally enclosed product zone** – Because of the completely enclosed design of all Acrison 'weight-loss' weigh feeders, product remains totally confined, thus assuring a clean dust-tight operation.
- **Minimum of moving parts** – All Acrison 'weight-loss' weigh feeders have been designed with a minimum number of moving parts to ensure the highest possible degree of reliability with lowest possible maintenance requirements. Longevity is exceptional.
- **Silent operation** – All Acrison weigh feeders are virtually silent when operating.

Model 407X with a Model 101-1 Metering Mechanism

To accurately and reliably meter a variety of free-flowing granular materials at feed rates ranging from about 10 pounds upwards to approximately 118 cubic feet per hour.

Model 101-1 Metering Mechanism

The Model 101-1 Feeder is a single auger mechanism specifically designed to meter free-flowing dry solid ingredients, primarily those of a granular nature. This basic rugged-duty mechanism is limited to those applications where the material is typically pelletized and/or flows very freely, but is not hygroscopic, moist, pressure sensitive and/or sticky. The feeder is powered by a single heavy-duty variable speed gearmotor.

The Model 407X-101-1 Weigh Feeder is available with several different size hoppers, the selection of which is based on the feed rate requirements, and the maximum number of refills (e.g., refills per hour) that will ensure optimum overall weigh feeder performance. The largest available hopper is 15 cubic feet in capacity.

An optional discharge gate, located at the bottom of the feed chamber, is available to allow rapid emptying through the bottom center of the feeder.

For additional information on the Model 101-1 Feeder, please reference Equipment Data Specifications 1-200-0479.

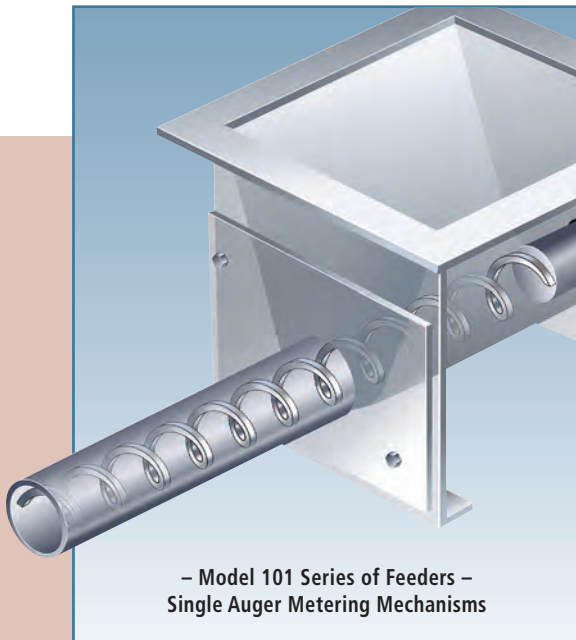

Model 407X-101-1

Model 407X with a Model 105X Metering Mechanism

To accurately and reliably meter a variety of dry solid materials at feed rates ranging from about 10 pounds upwards to approximately 40 cubic feet per hour.

Model 105 Series Metering Mechanisms

The Model 105 Series of Feeders utilize Acrison's dissimilar speed, *Double Concentric Auger Metering Mechanism*, universally recognized for its inherent ability to accurately and dependably meter an extremely broad variety of dry solid ingredients.

In operation, the unique '*Inter-Auger-Action*' produced by the rotation of the Double Concentric Augers '*conditions*' dry solid materials to a consistent state while effectively and reliably filling the centrally positioned metering auger from '*a full 360 degrees*'. The result is an exceptionally high degree of materials-handling versatility and superior all-around metering performance. The larger '*conditioning auger*' (Intromitter), and smaller metering auger, are mechanically geared together to operate at proportional,

but *dissimilar speeds*, powered by a common variable speed gearmotor.

The Model 105X Feeder is available with a number of different size hoppers, the selection of which is based on the feed rate requirements and physical handling characteristics of the material. The largest available hopper is 5 cubic feet in capacity.

For additional information on the Model 105 Series of Feeders, please reference Equipment Data Specifications 1-200-0480.



– Model 105 Series of Feeders –
Dissimilar Speed Double
Concentric Auger Metering Mechanisms



Model 407X-105X

Model SBC-3000 Weigh Feeder Controllers and Control Systems

Model SBC-3000 Weigh Feeder Controllers encompass leading-edge technologies and functional algorithms that provide unexcelled weigh feeder performance to satisfy the most demanding process requirements across a very broad range of applications. And with an unprecedented number of standard and optional features, accessories, and interfacing capabilities (including native Ethernet and Profibus connectivity), these controllers also provide unparalleled versatility, ease of use, and operational reliability. In particular, they are ideally suited for those applications that require central computer control with minimal hardware.

Model SBC-3000-DSP Controller

The Model SBC-3000-DSP Controller operates a single Acrison Weigh Feeder. Its design integrates a Model SBC-3000-CM Control Module with a bright, state-of-the-art TFT color graphics display measuring 7" diagonally. The assembly, designed for panel mounting, is dust-tight/water-tight.

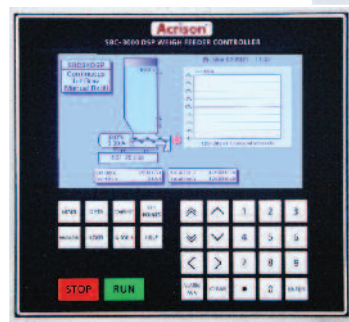

Model SBC-3000-CM Controller

The Model SBC-3000-CM Controller operates a single Acrison Weigh Feeder. It consists of a single circuit board (module) designed for applications that utilize a central computer, PLC or DCS for monitoring and control, which do not require a local operator interface. The Model SBC-3000-CM Controller is typically supplied in a card rack, the size of which depends upon how many SBC-3000-CM Controllers will be required for a given application. A local Keyboard/Display unit is available as an option.



Multi-Feeder Supervisory Control System (Acri-Data®)

Operation of the Models SBC-3000-DSP and SBC-3000-CM Controllers can be monitored and controlled by Acrison's *Acri-Data Multi-Feeder Supervisory Control System*. It is most commonly utilized in conjunction with Model SBC-3000-CM Controllers.

Operating with a 17 or 21 inch color touchscreen, Acri-Data is capable of supervising the operation and control of up to 20 Acrison Weigh Feeders while displaying real-time data and screen updates. It is also capable of master/slave and ratio-proportioning operation, unlimited recipe and storage and retrieval, trending, event and alarm logging, automatic shut-down configurability and more.

Acri-Data is hosted on a Microsoft Windows® operating platform (e.g., panel-mounted embedded PC, or a desktop/laptop PC). A user's PLC or DCS can also serve as a host for any of the above Weigh Feeder Controllers.

Equipment Specifications 1-200-0090.



Discover the difference!

We cordially invite you to witness a test in Acrison's state-of-the-art Customer Demonstration Facilities handling your actual product(s) with the specific equipment we recommend for the application. Usually, there is no cost or obligation for this service.

Discover the difference in technology, quality and performance of Acrison equipment.



Empire Boulevard Facility
Moonachie, NJ USA

Acrison products...

- Models 101 and 130 Volumetric Feeder Series
- Models V-101 and V-130 Volumetric Feeders
- Model 1015 Volumetric Feeder Series
- Model 105 Volumetric Feeder Series
- Model W-105 Volumetric Feeder Series
- Model 120 Volumetric Feeder
- Model 140 Volumetric Feeder Series
- Model 170 Volumetric Feeder Series
- Model 905-14 Volumetric Feeder
- Bin Discharger Feeders
- Model 200 Weigh Belt Feeder Series
- Model 203B Weigh Auger Feeder Series
- Model 270 In-Line Weigh Feeder Series
- Models 402, 404, 405, 406, 407X, 408 and 410 ('Weight-Loss') Weigh Feeders
- Model Series 403 ('Weight-Loss') Weigh Feeders
- Model 403B(D) Batch/Dump Weighing Systems
- Model 404BZ(BU) Bulk Bag Unloader Batch Weigher
- Models 350 and 301 Continuous Blenders and Blending Systems
- Multiple Auger Bin Dischargers and Multiple Auger Bin Discharger Hoppering Systems
- Vibratory Bin Discharger Hoppering Systems
- Model 170-BD-30 Bin Discharger
- Models 810 and 820 Bulk Bag Unloaders
- Models 500, 515, 530, and 580 Polyelectrolyte Preparation Systems
- Water and Waste Water Treatment Systems
- Volumetric and Gravimetric Feeder Controllers and Control Systems
- Silo Systems
- Accessory Equipment for Acrison Products
- Systems Engineering



Joseph Street Facility
Moonachie, NJ USA

"Visibly Different... Measurably Better"

Acrison[®], Inc.

20 Empire Blvd., Moonachie, NJ 07074

201-440-8300 • Fax: 201-440-4939

Toll Free: 800-4ACRISON

Email: informail@acrison.com

www.acrison.com